

# DCX Series

Installation and Maintenance Manual for the  
DCX203C and DCX203C-17A

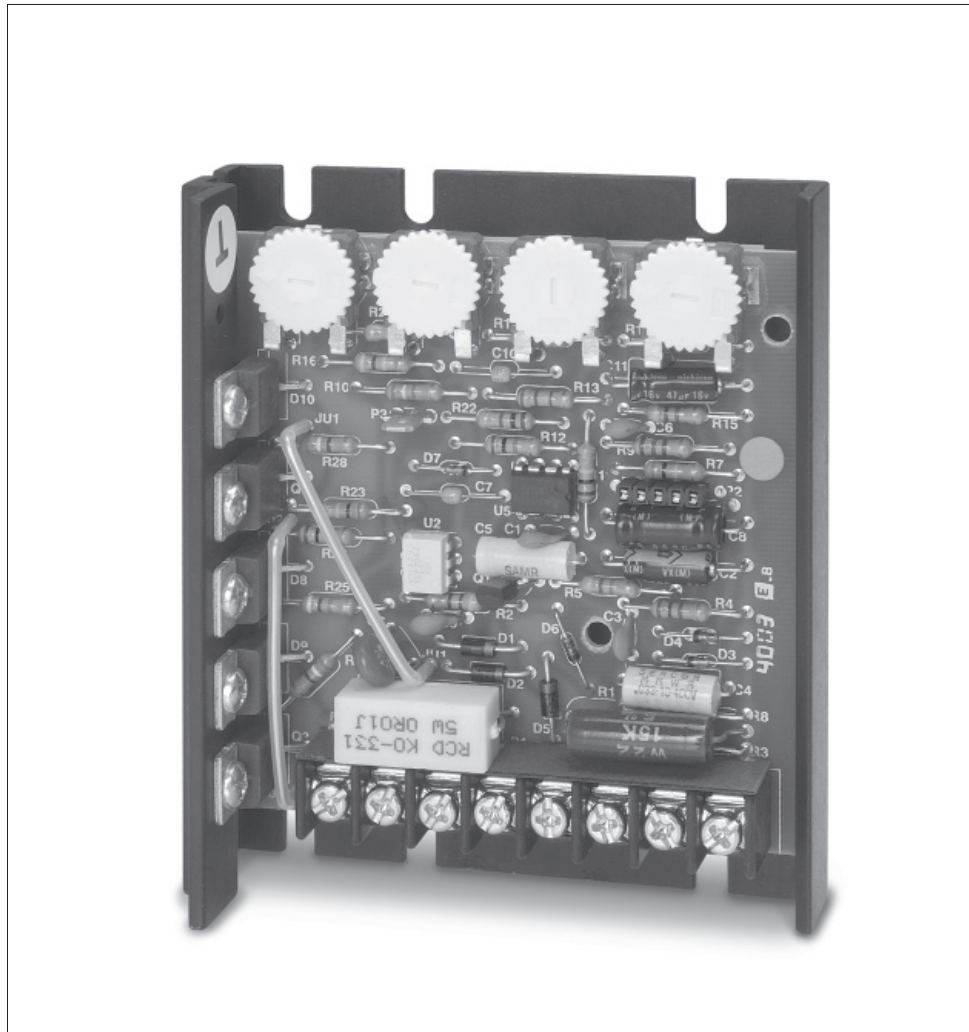

# TABLE OF CONTENTS

INTRODUCTION .....	2
CONTROL FEATURES .....	3
DCX SERIES HEATSINK DIMENSIONS .....	3
MOUNTING PROCEDURE .....	3
MODEL SELECTION .....	4
WIRING PROCEDURE & FUSING .....	4
TERMINAL STRIP WIRING INSTRUCTIONS .....	4
DCX SERIES HOOK-UP DIAGRAM .....	5
CONTROL START-UP .....	5
TRIMPOT ADJUSTMENT CHART & PROCEDURE .....	6
CONTROL MODIFICATIONS .....	7
TWO SPEED OPERATION .....	7
DYNAMIC BRAKING .....	7
TACH FEEDBACK/FOLLOWER .....	7
INHIBIT FUNCTIONS .....	7
SPEEDPOT KIT ASSEMBLY .....	8
OPTION DESCRIPTION .....	8-11
DC-25A OPTION .....	8-9
DC-RSW OPTION .....	9
DC-17A OPTION .....	10
DC-25D-DCX OPTION .....	10
DCX2-HTSK OPTION .....	11
KDPD OPTION .....	11
IN CASE OF DIFFICULTY .....	12
SPECIFICATIONS .....	13
TYPICAL MOTOR CURRENTS .....	13
WARRANTY .....	15

## WARNING

Improper installation or operation of this control may cause injury to personnel or control failure. The control must be installed in accordance with local, state, and national safety codes. Make certain that the power supply is disconnected before attempting to service or remove any components!!! If the power disconnect point is out of sight, lock it in disconnected position and tag to prevent unexpected application of power. Only a qualified electrician or service personnel should perform any electrical troubleshooting or maintenance. At no time should circuit continuity be checked by shorting terminals with a screwdriver or other metal device.

## INTRODUCTION

- The DCX variable speed control is rated from 1/8 HP through 1/2 HP with a 90 VDC output at 120 VAC input and 1/4 HP through 1 HP with a 180 VDC output at 240 VAC input. With DCX2-HTSK or suitable external heatsink, maximum U.L. rating can be increased to 1 HP@90VDC or 2 HP@180VDC and 10 AMPS D.C.
- The control is designed for DC Permanent Magnet, Shunt Wound, and some Universal (AC/DC) motors in the above horsepower ranges.
- Incoming AC voltage is converted to adjustable full wave rectified DC voltage to operate the DC motor. Also, a full wave field voltage is provided for shunt wound motors (see page 5 for voltages).
- The control incorporates transient voltage protection with adjustable current limit which fits into a compact package. It features adjustable minimum and maximum speeds along with adjustable IR compensation and an inhibit function.
- cULus Recognized under, U.L. File # E352602.

# CONTROL FEATURES

**MINIMUM SPEED** - Allows adjustment of the motor speed when the speedpot is set at minimum (CCW). This permits the user to eliminate "Deadband" on the main speed control, permitting zero calibration. Clockwise rotation of "MIN" trimpot increases speed.

**MAX SPEED (Maximum Speed)** - Allows adjustment of the motor speed when the speedpot is set at maximum (CW). This permits the user to eliminate the top end "Deadband", which will provide full speed at maximum rotation. Rotation of the "MAX" trimpot in the clockwise direction increases the maximum motor speed.

**IR COMP (Speed Regulation)** - This allows for adjustment of the circuitry that controls the speed regulation of the motor. The circuitry controls armature speed by changing the armature voltage to compensate for increased or decreased motor loading. Clockwise rotation of the "IR COMP" trimpot will increase compensation.

**CUR. LIM. (Current Limit)** - Provides protection from excessive armature current by limiting the maximum armature current the control can provide. This enables adjustment of the maximum torque the motor can deliver. Torque adjustment (Cur. Lim.) is preset at 125% of rated motor torque (current) based on horsepower. Clockwise rotation of the "CUR. LIM." trimpot increases the torque (current) the control will provide.

**INHIBIT TERMINAL PIN** - Allows the user a choice of stopping and starting hard (fast) or stopping hard with a soft start through an adjustable acceleration ramp, without breaking the AC lines (see page 7).

**TERMINAL STRIP** - Allows for connection of AC lines, motor leads, motor field (if needed), and speed potentiometer

## DCX SERIES HEATSINK DIMENSIONS

### DCX203C HEATSINK

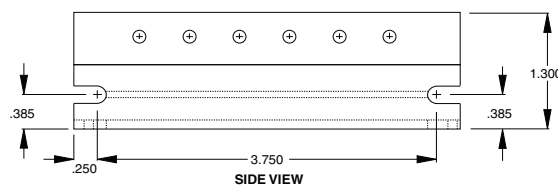
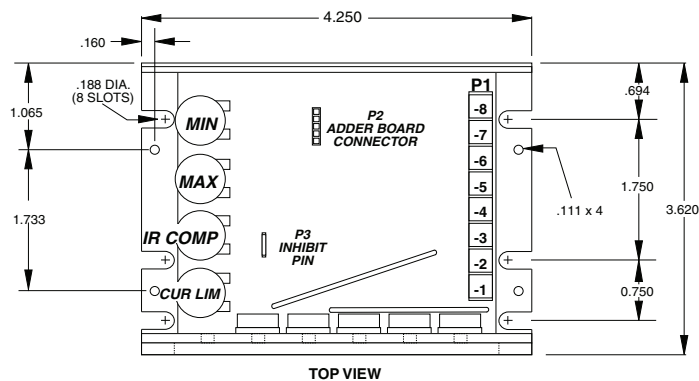

## MOUNTING PROCEDURE

1. Eight 3/16" wide slots are provided for control mounting.
2. Control chassis can be used as a template.
3. Use standard hardware to mount.

### CAUTION:

DO NOT MOUNT WHERE AMBIENT TEMPERATURE IS OUTSIDE THE RANGE OF -10° C (15° F) TO 45° C (115° F)

# MODEL SELECTION

HORSEPOWER RANGE	INPUT VOLTAGE	OUTPUT VOLTAGE	OUTPUT AMPS DC	ACCEL / DECEL	PART NUMBER
1/8 thru 1/2	120 VAC	0-90 VDC	5.5A	FIXED 0.5 SEC.	DCX203C
1/8 thru 1/2	120 VAC	0-90 VDC	5.5A	ADJUSTABLE 0.5 - 8 SEC.	DCX203C-17A
1/4 thru 1	240 VAC	0-180 VDC	5.5A	FIXED 0.5 SEC.	DCX203C
1/4 thru 1	240 VAC	0-180 VDC	5.5A	ADJUSTABLE 0.5 - 8 SEC.	DCX203C-17A

## WIRING PROCEDURE & FUSING

1. Size all wires which carry armature or line currents **AS SPECIFIED BY NATIONAL, STATE, AND/OR LOCAL CODES**. All other wires may be # 18 AWG or smaller as permitted by local code.
2. Separate control wires from the armature and AC lines when routed in conduit or in wire trays.
3. Fusing - The motor and control are protected against overloads by the current limit circuit and a customer installed fuse in the AC line. **THIS PROTECTION ALREADY MAY BE PROVIDED BY THE CUSTOMER WITH CIRCUIT BREAKERS OR FUSES IN BOTH MAIN LINES. IF NOT:**

FOR 120 VAC INPUT - fuse protection should be added by the customer in AC Line 1 (see following chart)

FOR 240 VAC INPUT - fuse protection should be added by the customer in AC Line 1 and Line 2 (see following chart)

### FUSING ADDED BY CUSTOMER (Bussman ABC or Little Fuse 314 Series ceramic fuses)

HORSEPOWER	120 VAC INPUT	HORSEPOWER	240 VAC INPUT
1/8	2 AMP	1/4	2 AMP
1/4	4 AMP	1/3	3 AMP
1/3	6 AMP	1/2	4 AMP
1/2	8 AMP	3/4	6 AMP
		1	8 AMP

## TERMINAL STRIP WIRING INSTRUCTIONS

The DCX Series uses an 8 position terminal strip for ease of connection.

- P1-1,2 (AC or L) 120 VAC - Connect incoming hot AC or L (black wire) to P1-1 and neutral AC or N (white wire) to P1-2.  
(AC or N) Connect ground (green wire) to CHASSIS of control.  
240 VAC - Connect both hot sides (L & N), one to P1-1 and one to P1-2. Connect ground wire to CHASSIS of control.
- P1-3 (+Arm) Connect to PLUS (+) Armature wire on motor. 0-90 VDC for 120 VAC input or 0-180 VDC for 240 VAC input. See "SPECIFICATIONS" for output rating.
- P1-4 (-Arm/-Field) Connects to MINUS (-) Armature wire on motor and, if necessary, connect MINUS (-) Field wire of SHUNT WOUND MOTOR.
- P1-5 (+Field) DO NOT use for Permanent Magnet Motor. This supplies +Field voltage for a SHUNT WOUND MOTOR (refer to field voltage table). For motors with dual voltage field (ie. 50/100V or 100/200V), make sure highest value is connected.
- | FIELD VOLTAGE TABLE |     |     |
|---------------------|-----|-----|
| VAC INPUT           | 120 | 240 |
| VDC FIELD           | 100 | 200 |
- P1-6 (Speedpot Hi) Connects to high side (white wire) of Speedpot (CW end). This is internal +12 volts. For start-stop applications, the connection between this terminal and Speedpot HI can be opened and closed by a SPST switch. INPUT MUST NOT BE GROUNDED!
- P1-7 (Speedpot Wiper) Connects to wiper (red wire) of Speedpot (center lead). For Voltage Follower applications, this INPUT MUST NOT BE GREATER THAN +12V MAXIMUM AND MUST NOT BE GROUNDED!
- P1-8 (Speedpot Lo) Connects to Low side (orange wire) of 5K Speedpot (CCW end). This input is raised and lowered by the MIN. trimpot (5K). Electronic speed input (voltage follower) may be referenced to speedpot LO if the MIN trimpot adjustments are to be active. Otherwise, inputs may be referenced to -ARM, which will bypass the MIN trimpot. INPUT MUST NOT BE GROUNDED!

Warning:

1. Be sure the control housing is properly grounded.
2. Armature connections must not be switched or broken while the control is on. Serious control damage may result.
3. For non-speedpot applications, the input connection to the LO, WIPER, and HI terminals must not be grounded! Serious control damage may result from a grounded input.

## DCX SERIES HOOK-UP DIAGRAM

Warning:

**Do not attempt to perform Hi-pot test across AC lines with control in circuit. This will result in immediate or long term damage to the control.**

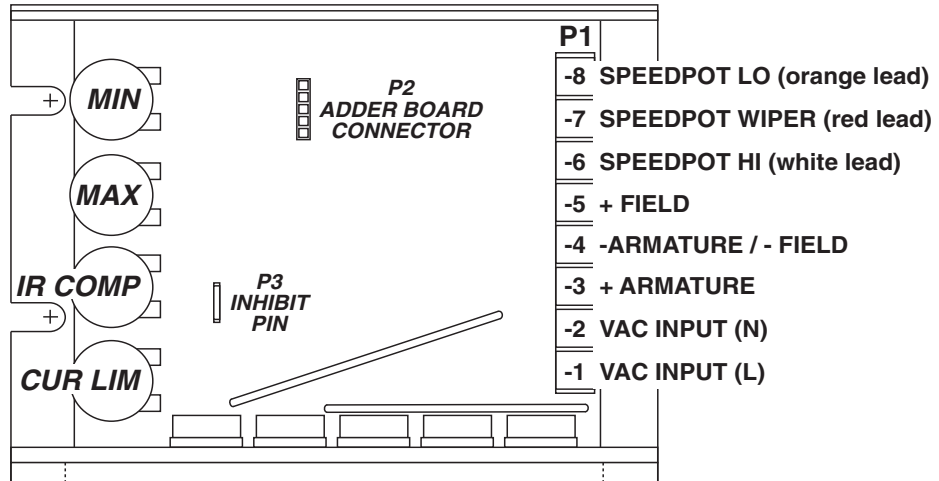

## CONTROL START-UP

**WARNING: ALL POWER MUST BE TURNED OFF BEFORE PROCEEDING!**

1. Recheck all wiring. Accidental grounds, loose or pinched wires on armature or speedpot wires may damage the control when power is applied.
2. Check to see that incoming service is the correct voltage.
3. Turn speedpot to zero (fully CCW).
4. Turn power on, and advance speedpot while observing motor. Power must be off before step 5 can be accomplished!
5. If motor rotation is incorrect, turn power off at external disconnect and reverse +ARM and -ARM connections.
6. Check for satisfactory operation throughout the speed range.
7. If operation is satisfactory, no readjustments are needed.
8. If instability or surging is observed, or if maximum speed is higher than desired, see "TRIMPOT ADJUSTMENT CHART " below.
9. For other problems, consult page 12, "IN CASE OF DIFFICULTY".

# TRIMPOT ADJUSTMENT CHART & PROCEDURE

Settings apply when using a 5K ohm master speedpot. This chart is used in conjunction with the adjustment procedure and is approximate.

	C.L.	IR	MAX	MIN	HP
<b>DCX SERIES</b> 120 VAC input; 0-90 VDC output					<b>1/8</b>
					<b>1/4</b>
					<b>1/3</b>
					<b>1/2</b>
					<b>3/4*</b>
					<b>1.0*</b>

Operation of the control beyond  $\pm 10\%$  of the normal line voltage could result in re-adjustment. These adjustments are permanent; periodic re-adjustment is normally not needed.

Settings apply when using a 5K ohm master speedpot. This chart is used in conjunction with the adjustment procedure and is approximate.

HP	C.L.	IR	MAX	MIN	
<b>1/4</b>					<b>DCX SERIES</b> 240 VAC input; 0-180 VDC output
<b>1/3</b>					
<b>1/2</b>					
<b>3/4</b>					
<b>1.0</b>					
<b>1.5*</b>					
<b>2.0*</b>					

**\* NOTE: ADDITIONAL CUSTOMER HEATSINK (DCX2-HTSK) REQUIRED FOR 120 VAC INPUT - GREATER THAN 1/2 H.P. MOTORS AND 240 VAC INPUT - GREATER THAN 1 H.P. MOTORS. EXTRUSION TEMPERATURES SHOULD NOT EXCEED 70 DEGREES C.**

TRIMPOT	FUNCTION	ADJUSTMENT
<b>MIN.</b>	Sets minimum motor speed when speedpot is set at zero. CW rotation will increase minimum motor speed.	<ol style="list-style-type: none"> <li>1. Set Speedpot to zero (fully CCW).</li> <li>2. Rotate MIN trimpot CW until motor starts to rotate.</li> <li>3. Slowly rotate MIN trimpot CCW until motor stops.</li> </ol> <p>NOTE: If motor rotation is desired, rotate MIN trimpot CW until desired MIN speed is reached.</p>
<b>IR COMP</b>	Provides a means of improving motor speed regulation in the armature feedback mode. If a slowdown due to load change is of no concern, rotate this trimpot fully CCW.	<ol style="list-style-type: none"> <li>1. Set Speedpot at 50%.</li> <li>2. Observe motor speed at no load condition.</li> <li>3. Apply full load to motor.</li> <li>4. Turn IR COMP trimpot CW to obtain the same motor speed as with no load.</li> </ol>
<b>MAX.</b>	Sets maximum motor speed when speedpot is set at maximum (fully CW rotation). CW rotation of MAX trimpot increases maximum motor speed.	<ol style="list-style-type: none"> <li>1. TURN DRIVE POWER OFF!!</li> <li>2. Connect a DC Voltmeter: + to +ARM, and - to -ARM. <b>NOTE: Meter must not be grounded!!</b></li> <li>3. Set meter voltage range: (90 VDC for 120 VAC, 180 VDC for 240 VAC).</li> <li>4. Turn power on. Set Speedpot at 100%.</li> <li>5. Adjust MAX trimpot to rated motor armature voltage as shown on meter. NOTE: A tachometer or strobe may be used in lieu of a meter. Follow above steps, except adjust MAX trimpot to rated motor base speed indicated by tachometer or strobe.</li> </ol>
<b>CUR.LIM.</b>	Limits DC motor armature current (torque) to prevent damage to the motor or control. The current limit is set for the rated motor current. CW rotation of this trimpot increases the armature current (or torque produced).	<ol style="list-style-type: none"> <li>1. TURN DRIVE POWER OFF!!</li> <li>2. Connect a DC Ammeter between A1 on motor and +ARM on control. This is in series with the motor.</li> <li>3. Turn power on.</li> <li>4. Set Speedpot at the 50% position.</li> <li>5. Apply friction braking to motor shaft until motor stalls.</li> <li>6. With motor stalled, set current at 125% of rated motor armature current by adjusting CUR. LIM . trimpot.</li> </ol>

# CONTROL MODIFICATIONS

## TWO SPEED OPERATION

Two pot operation is done using two 10K ohm speed potentiometers in parallel (both HI's to P1-6, both LO's to P1-8). The WIPER is switched using a SPDT switch.

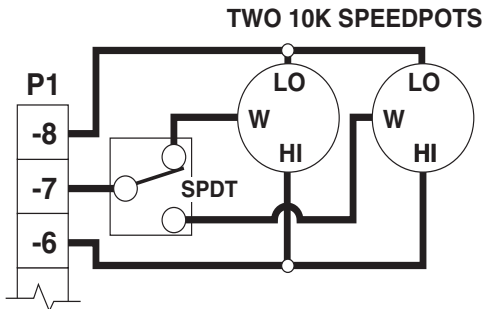

## DYNAMIC BRAKING

A DPDT switch is used to inhibit the control and to connect the DBR. Typical values for the DBR (dynamic brake resistor) are 5 ohms for 120V, 10 ohms for 240V (both 35W to 50W). Note that motor horsepower, inertia, and cycle time effect sizing of the DBR. NOTE: When used with the DCX203C-17A model or the DC-17A option board the Decel pot should be set full CCW.

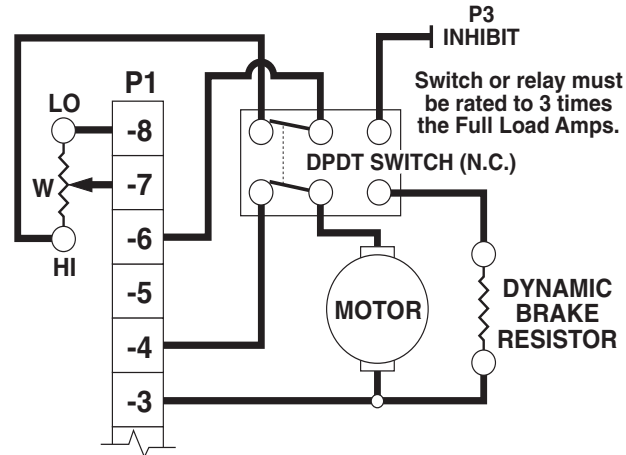

## TACHOMETER FEEDBACK

Improves speed regulation to  $\pm 1/2\%$  of base speed.

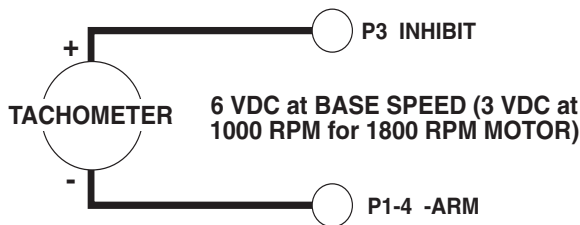

## TACHOMETER FOLLOWER

Allows control output to follow tachometer voltage.

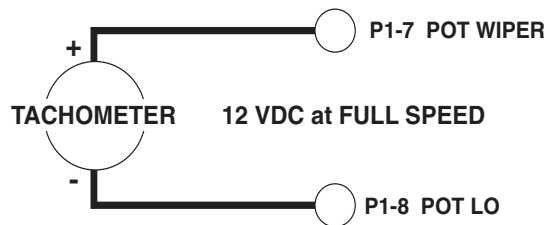

NOTE: NEED 1% OR LESS - TACH OUTPUT RIPPLE

## INHIBIT (USED INDEPENDENTLY)

The customer supplied SPST switch is connected in series between the speedpot HI (P1-6) and the Inhibit pin (P3). To inhibit (stop motor), speedpot HI is closed to the Inhibit pin. To restart, the switch is returned to open. NOTE: The control will stop and start fast.

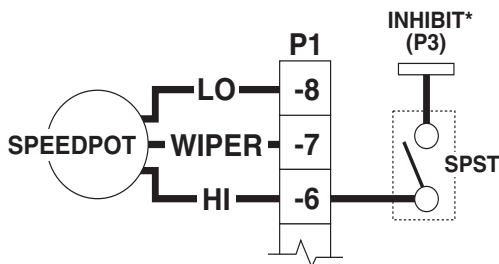

## INHIBIT (USED WITH SPEEDPOT)

The Common of the SPDT switch is connected to control pot HI and is switched between Speedpot Hi and the Inhibit pin (P3). To inhibit (stop motor), speedpot HI is closed to the Inhibit pin. To restart, the switch is returned to Speedpot Hi. NOTE: The control will stop fast and soft start through a fixed acceleration range.

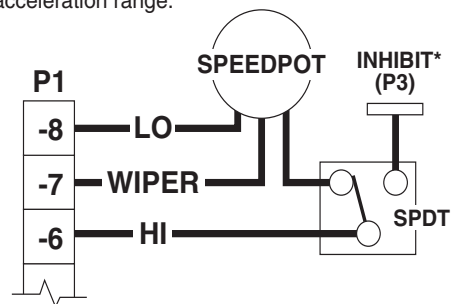

NOTE: Permits starting and stopping of motor without breaking AC lines. In the event of SCR failure or false triggering, the Inhibit circuit will not stop motor.

\* Always use a shielded wire when connecting to the inhibit terminal. The shield should be connected to terminal P1-4 (-ARM) which is control Common.

# SPEEDPOT KIT ASSEMBLY

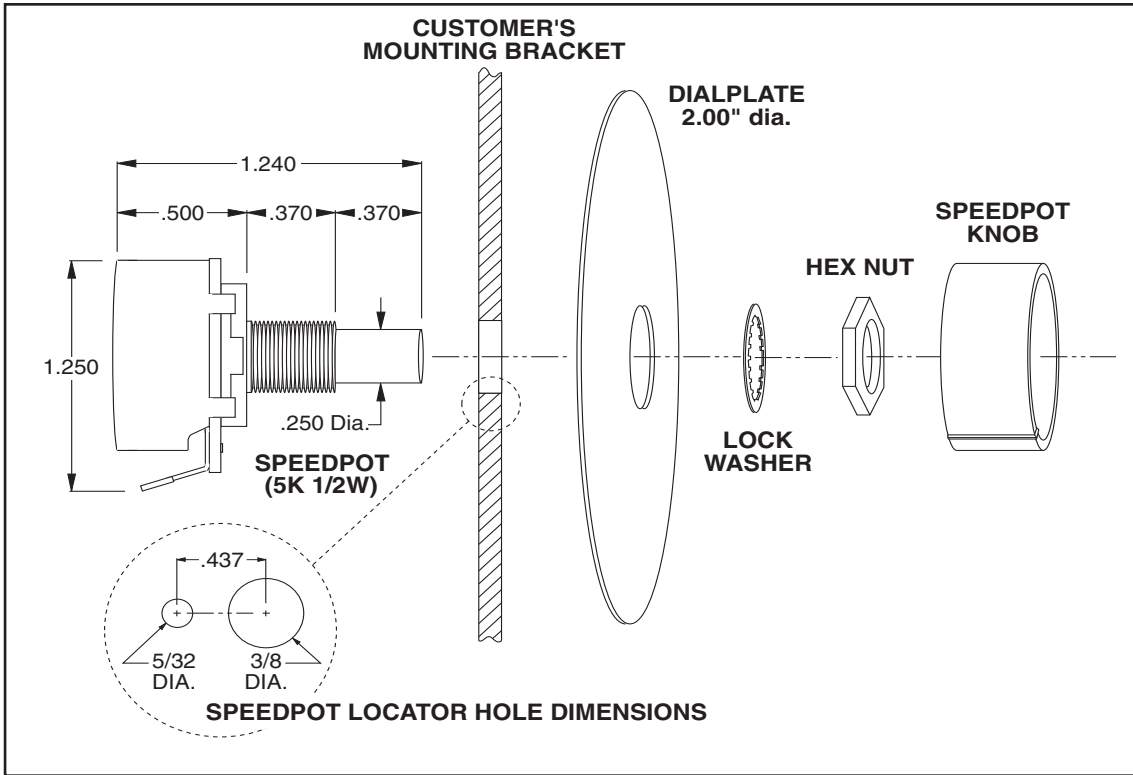

## OPTION DESCRIPTIONS

### *DC-25A option*

Isolated 4-20 mA Signal Follower

Field Installed  
Available All Models

DO NOT USE TRIMPOT CHART TO ADJUST MIN AND MAX TRIMPOTS ON MAIN BOARD.

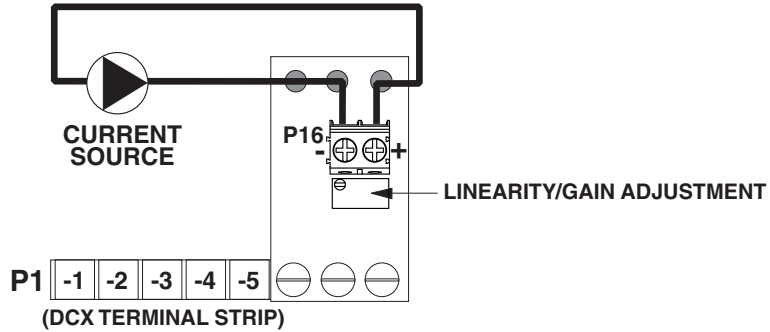

Note:  
See DC-25A Setup Procedure Page 9



## DC-25A SETUP PROCEDURE

The DC-25A option is a 4-20 mA isolated signal card that replaces the speedpot to control speed. The 4-20 mA signal input can be either grounded or ungrounded. The board sets on spacers screwed to the pot HI, Wiper, and LO terminals on the main board using long screws. The current source connects to the + and - two position terminal strip (P16-1 and -2) on the DC-25A option board. The Linearity trimpot on the DC-25A option board is set at the factory for proper linearity, however this trimpot may need to be re-set after tuning the Max and Min trimpot settings on the control for your specific application. If needed then refer to the setup procedure below.

The following is the recommended procedure to set up the DC-25A option on the DCX Series:

- 1) With the DCX oriented so that trimpots are along the top, adjust Min trimpot to minimum (full CCW) and Max trimpot to 50%. The voltage is set below the typical motor voltage to make certain the drive is NOT in saturation before setting the DC-25A board saturation point.
- 2) Set the Linearity/gain pot on the DC-25A full CW. This is a 20 turn pot and you should hear a clicking with each turn when fully up or just count 20 turns.
- 3) Make certain your motor is connected to +/-ARM output of the drive and source power for the control is turned on. (Note: For proper tuning this setup is best done on an unloaded motor.)
- 4) With power applied and a voltmeter monitoring motor output Vdc, apply 4mA to DC-25A board. Check voltmeter reading and adjust the Linearity/gain trimpot, R16, on the DC-25A board CCW until motor output voltage is less than 0.1Vdc.
- 5) Now apply 20mA to the DC-25A board and adjust the Max trimpot to a voltage that is 5 volts above the final desired max motor voltage output. Adjust the Linearity/gain trimpot on the DC-25A board CCW until the motor output voltage decreases to the desired max voltage set point.
- 6) Now, apply 4mA to the DC-25A board again and adjust the Min trimpot to deadband or the desired minimum motor voltage output. The deadband point is when you are at 0Vdc and any further increase of the Min trimpot would result in an output to the motor. Re-apply 20mA to the DC-25A board and verify max output has not changed. A small adjustment may be needed to the Max trimpot to reset to desired max output.
- 7) Adjust 4-20 input to 12mA. If tuned properly the output voltage of an unloaded motor should be within a few volts of 1/2 output (based on max output setting above).

## DC-RSW option

### Manual Forward-Off-Reverse Switch

Field Installed Only

Permits reversing of motor. This is accomplished using a 4PDT blocked center switch. When switched between the forward/reverse positions, a delay is encountered due to the blocked center position, which protects the control from any voltage that may be at the ARM terminals. The center position is OFF/NEUTRAL.

**THE MOTOR MUST COME TO A COMPLETE STOP BEFORE CHANGING DIRECTIONS. IF THE MOTOR DOES NOT COME TO A COMPLETE STOP, SERIOUS DAMAGE TO THE CONTROL MAY RESULT. BYPASS OF THE SWITCH CENTER BLOCK MAY RESULT IN DAMAGE TO THE CONTROL.**

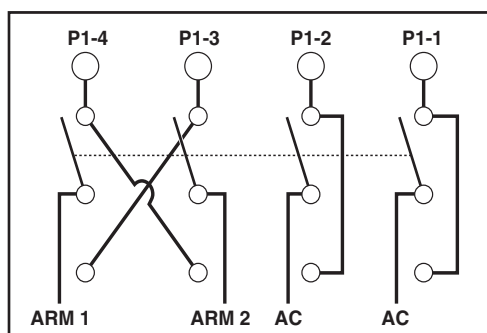
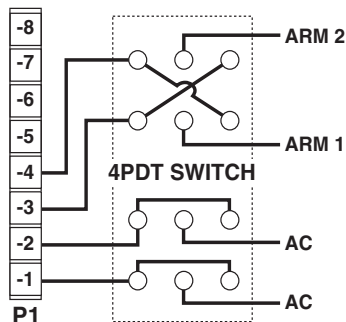

# DC-17A

## Individually Adjustable Linear Accel and Decel

Field Installed

This Model uses the DCX203C with a board that plugs into the five position expansion connector. The DC-17A overrides the fixed accel ramp built into the DCX203C control, providing independently adjustable linear accel and decel from 0.5 to 8.0 seconds. To install, flip over the DC-17A board so the printed circuit lines are visible. Align the male connector CN1 (DC-17A) with the female connector P2 (DCX203C) so terminal CN1-1 fits into P2-6, CN1-2 in P2-5, etc. Align the plastic stand-off on the DC-17A board with the hole shown on the DCX203C main board. Once connectors and stand-off are aligned, snap into place. Adjustment of both trimpots is accomplished via the labeled access holes on the back side of the DC-17A board. Full CCW rotation equals minimum accel or decel time and full CW rotation equals maximum accel or decel time. Note: Each trimpot operates independently of the other.

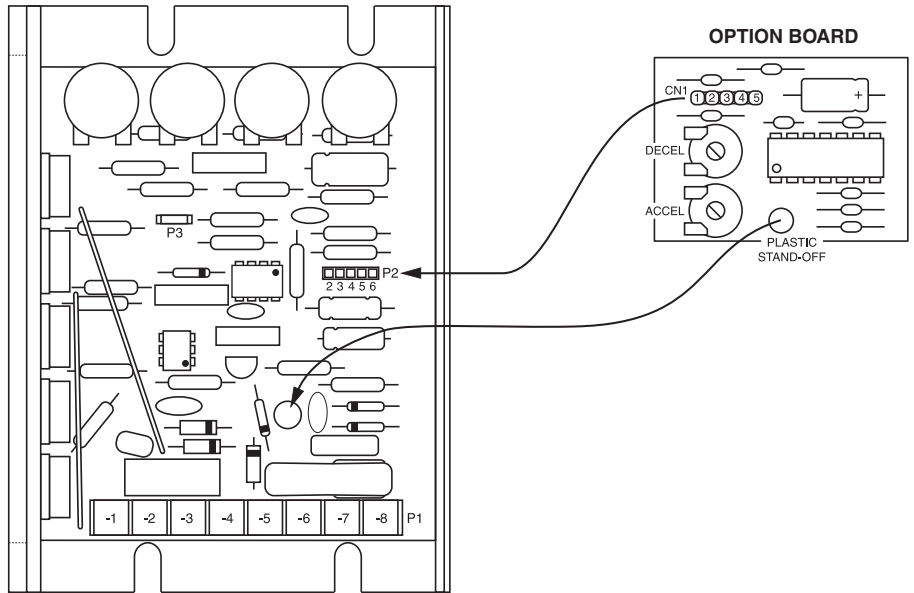

DCX203C SERIES BOARD

# DC-25D-DCX

## REMOTE ISOLATED SIGNAL CARD

FIELD INSTALLED

### Remote Signal Input

This feature allows for the use of either a grounded or non-grounded remote DC signal such as 0 to 5 through 0 to 250Vdc, 4-20mA current, or a remote speed pot. The DC input signal type can be selected for voltage (Vin) or current (I4-20) via the JP2 jumper clip. There is a Hi/Lo range jumper selection that should be set to the (Lo) setting when using a 4-20mA signal or voltage ranges of 0-5 through 0-25Vdc. When using voltage ranges of 0-25 through 0-250 this jumper must be set to (Hi). The GAIN trimpot is used to set full linear output in reference to the input signal range. The output of this remote signal isolation board is a linear signal that is proportional to the remote input signal being supplied.

### CAUTION

**The Min and Max settings in the TRIMPOT ADJUSTMENT CHART may differ from the final settings achieved when using directions in the following SET-UP PROCEDURES.**

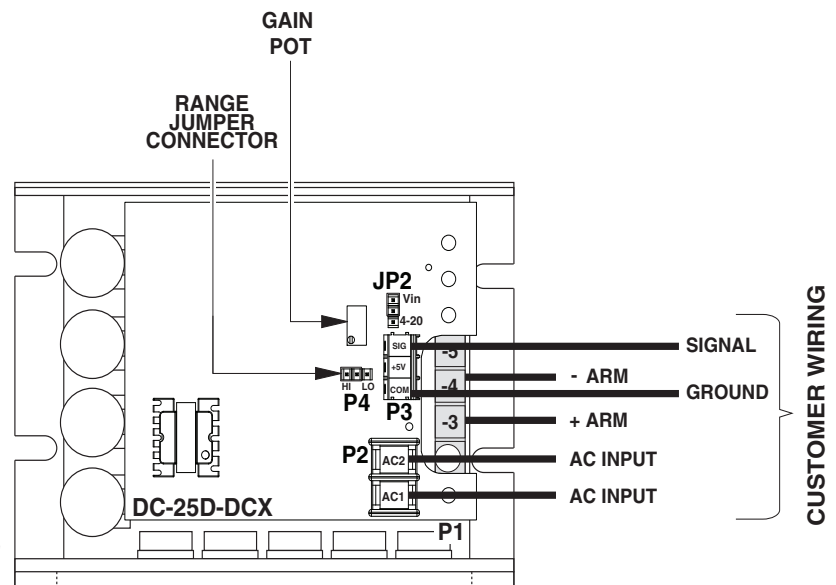

### Set-up Procedure When Using Remote Signal Input

1. With NO power to control, connect a DC Voltmeter to control outputs as follows: Meter COMMON to the -ARM terminal, Meter POSITIVE to the +ARM terminal. Select correct meter range (0-90V or 0-180V).
2. Preset GAIN pot on the remote signal board fully CCW.
3. Place the JP2 jumper clip in the proper position based on the input signal being used.
4. Place the P4 jumper clip in the Lo position for 4-20mA signals or voltage signals less than 25Vdc. Place the P4 jumper clip in the Hi position for voltage signals greater than 25Vdc. (NOTE: Never exceed 250Vdc)
5. Make sure all connections are properly made per the hookup connection diagram and then apply AC power to the controller.
6. Set the remote input signal to its lowest setting. Adjust the MIN trimpot to deadband (the point just before an increase causes an output).
7. Apply the maximum remote input signal. Motor should start to run. Adjust the GAIN pot CW until no further increase in control output voltage occurs and then decrease the gain pot slowly until output voltage to the motor drops approximately 5Vdc.
8. Set the MAX trimpot on the control to the correct motor voltage.
9. Some interaction between trimpots may occur. Recheck the Min trimpot setting and repeat steps 6 through 8 as needed.

# DCX2-HTSK

This provides additional suitable external heatsink to allow the control to output maximum U.L. output Amps of 10 Amps D.C.

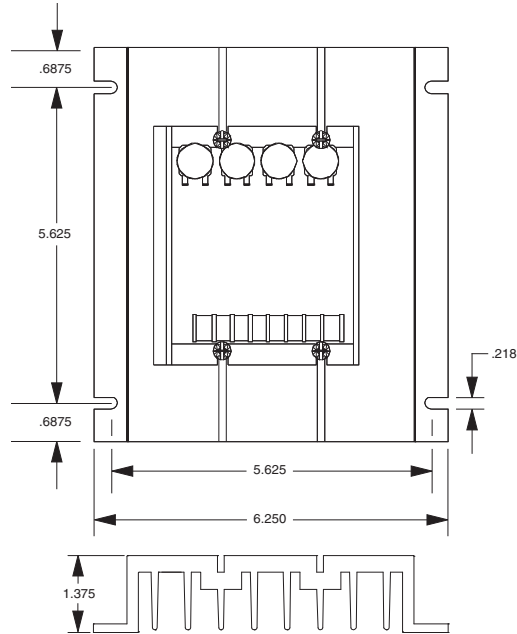

# KDPD

This is a replacement pot kit used to control the speed of the motor

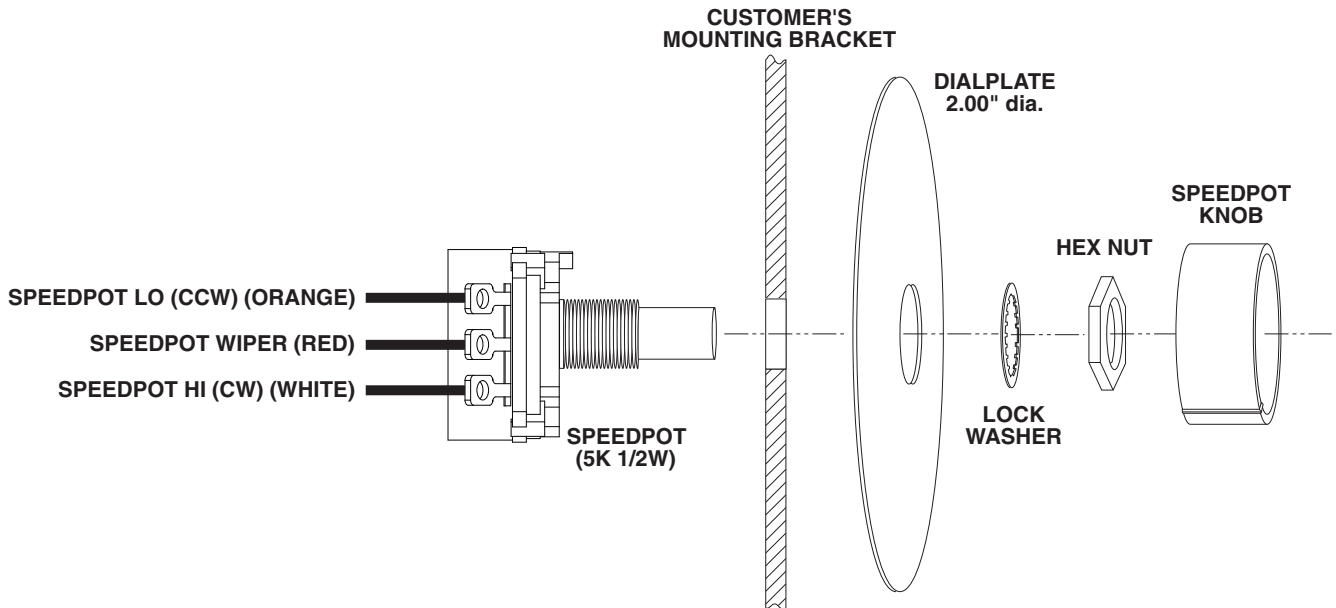

# IN CASE OF DIFFICULTY

PROBLEM	POSSIBLE CAUSE(S)	CORRECTIVE ACTION(S)
Motor doesn't operate	<ul style="list-style-type: none"> <li>- Blown Fuse or Breaker</li> <li>- Incorrect or no power source</li> <li>- Speedpot set at Zero</li> <li>- Worn motor brushes</li> </ul>	Replace Fuse or reset breaker Install proper service Adjust Speedpot CW to start Replace brushes
Armature output voltage cannot be adjusted, output is a constant DC level  Motor stalls, or runs very slowly with speed control turned fully CW	<ul style="list-style-type: none"> <li>- No motor or load connected</li> <li>- Speedpot low connection open</li> <li>- Low Voltage</li> <li>- Overload Condition</li> <li>- Worn motor brushes</li> <li>- MAX SPEED set incorrectly</li> </ul>	Check that motor or load is connected to armature terminals Check that speedpot low wire is connected  Check that VAC is above 100VAC Reduce load or increase motor size and/or C.L. setting. Replace brushes See TRIMPOT ADJUSTMENT PROCEDURE
Motor hunts	<ul style="list-style-type: none"> <li>- Motor current less than 150mA</li> <li>- Too much IR COMP</li> <li>- Motor is in current limit</li> <li>- Motor speed is above rated speed</li> <li>- Max set too high</li> </ul>	Motor current must be greater than 150mA D.C. See TRIMPOT ADJUSTMENT PROCEDURE See TRIMPOT ADJUSTMENT PROCEDURE Reduce Speed See TRIMPOT ADJUSTMENT PROCEDURE
Repeated fuse blowing	<ul style="list-style-type: none"> <li>- Low Voltage</li> <li>- Overload Condition</li> <li>- Worn motor brushes</li> <li>- Defective motor bearings</li> <li>- Defective electrical components</li> </ul>	Check-should be above 100V or 208V Reduce load Replace Replace Call Boston Gear

If control still will not operate, go to [www.bostongear.com](http://www.bostongear.com) or call (800) 825-6544.

# SPECIFICATIONS

AC input voltage .....  $\pm 10\%$  of rated line voltage  
 Acceleration ..... 0.5 seconds  
 Amps - DC output ..... 150 mA to 5.5 ADC  
 Controller overload capacity ..... 200% for one minute  
 Current limit trimpot range ..... 1 to 15 ADC  
 Deceleration ..... 0.5 seconds  
 Dimensions and weights:

	WIDTH	LENGTH	DEPTH	WEIGHT
ENGLISH	3.625"	4.250"	1.300"	8.00 oz.
METRIC	92mm	108mm	33mm	228 gms.

Drive service factor ..... 1.0  
 Efficiency ..... 85% typical  
 Input frequency ..... 50 or 60 Hertz  
 Max. trimpot speed range ..... 60% to 110% of base speed  
 Min. trimpot speed range ..... 0% to 30% of maximum speed  
 Power devices ..... isolated case tab  
 Shunt field voltage ..... 100VDC for 120VAC input; 200VDC for 240VAC input; 1 amp maximum  
 Speed control ..... via 5k Ohms 1/2W potentiometer or 0-10VDC isolated signal  
 Speed range ..... 50:1  
 Speed regulation .....  $\pm 1\%$  of base speed  
 Temperature range .....  $-10^{\circ}$  to  $45^{\circ}$  C. ambient ( $15^{\circ}$  to  $115^{\circ}$  F)  
 Transient protection ..... G-Mov  
 Trigger ..... opto-coupler  
 Type ramp of accel/decel ..... RC time constant

## TYPICAL MOTOR CURRENTS

Horsepower	1/8	1/4	1/3	1/2	3/4	1.0
Typical AC Amps (120VAC)	1.60	3.50	4.40	6.50	-----	-----
Typical Arm Amps (120VAC)	1.20	2.70	3.40	5.00	-----	-----
Typical AC Amps (240VAC)	-----	1.80	2.20	3.30	4.80	6.50
Typical Arm Amps (240VAC)	-----	1.40	1.70	2.50	3.70	5.00



# Boston Gear DC Controls Warranty

**Boston Gear** warrants its products to be free from defects in material and workmanship.

The exclusive remedy for this warranty is Boston Gear factory replacement or repair of any part or parts of such product which shall within 12 months after delivery to the purchaser be returned to Boston Gear factory with all transportation charges prepaid and which Boston Gear determines to its satisfaction to be defective.

This warranty shall not extend to defects in assembly by other than Boston Gear or to any article which has been repaired or altered by other than Boston Gear or to any article which Boston Gear determines has been subjected to improper use.

Boston Gear assumes no responsibility for the design characteristics of any unit or its operation in any circuit or assembly.

This warranty is in lieu of all other warranties, express or implied; all other liabilities or obligations on the part of Boston Gear, including consequential damages, are hereby expressly excluded.

**NOTE:** Carefully check the control for shipping damage. Report any damage to the carrier immediately. Do not attempt to operate the drive if visible damage is evident to either the circuit or to the electronic components.

All information contained in this manual is intended to be correct; however information and data in this manual are subject to change without notice. Boston Gear makes no warranty of any kind with regard to this information or data.

Further, Boston Gear is not responsible for any omissions or errors or consequential damage caused by the user of the product.

Boston Gear reserves the right to make manufacturing changes which may not be included in this manual.



An Altra Industrial Motion Company

Boston Gear  
701 Carrier Drive  
Charlotte, NC 28216  
[www.bostongear.com](http://www.bostongear.com)  
Customer Service 800-825-6544