

CENTRIC OVERLOAD RELEASE CLUTCHES

10





In 1998, Boston Gear acquired the Centric Clutch Company. In 1948, Centric Clutch started manufacturing centrifugal clutches for a wide range of industries. These clutches were originally designed as a means to connect power in a drive train with soft start and delay capabilities. Centric's centrifugal clutch was the industry's first overload protection device with repeatable performance. The Boston Gear/Centric centrifugal clutch offers many advantages in electric motor and engine drive applications. Utilizing a centrifugal clutch enables the selection of normal torque motors for running loads rather than the selection of high torque motors for starting loads. The centrifugal clutch also sharply reduces the motor starting current requirements and heat losses inherent to the direct starting of a drive. This adds up to reduce power factors greater efficiency and therefore, greater economy in motor drives.

When used with engine drives, the spring controlled centrifugal clutch allows the engine to warm up before starting the load or to stand by at an idling speed. Thus the spring controlled centrifugal clutch is used to great advantage in such applications as dual drives and engine pumping systems. This style clutch also can be used with turbines where a warm up period is necessary.

On any drive, the Boston Gear Centric centrifugal clutch provides protection against the shock loads which occur in the starting of a rigidly coupled drive. In many cases, these loadings are capable of seriously damaging components of the drive. Often expensive safety factors have to be designed into the machinery to protect against these loadings. The use of a centrifugal clutch also has inherent overload protection. If for some reason the driven machinery develops an overload condition, the clutch capacity will be exceeded and the clutch will slip, protecting the driving machinery.

The use of a Boston Gear Centric centrifugal clutch allows the designer of a particular drive complete flexibility in clutch selection as each clutch is made, to order. Friction shoes of specific weights are custom designed, therefore, any capacity within a particular size can be obtained. The same holds true in the case of the spring controlled clutch. This style of clutch is designed to provide the specific engagement or disengagement speeds required by a specific application.

OPERATING PRINCIPLES

Boston Gear Centric centrifugal clutches utilize two basic force principles in their operation, centrifugal force and friction force. Centrifugal force is that force which tends to pull a rotating body away from the center of rotation. Friction force exists between any two bodies in contact where one of the bodies is trying to move relative to the other body.

Figure 1, a face view of a centrifugal clutch, shows the basic components of the device. The driver half or spider is mounted to the motor or engine shaft and the driven half is connected to the load either directly or by an indirect drive arrangement. The friction shoes are the connecting element between the driver and the drum.

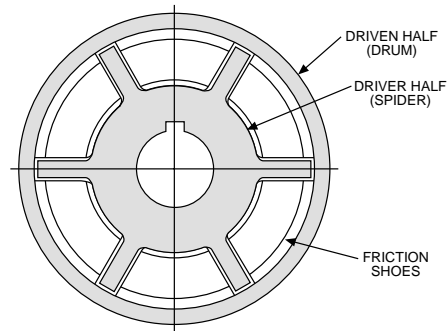

Figure 1

When the drive is set in motion, the spider and the shoes start to rotate. The spider imposes a driving force (F_3) on the friction shoes as shown in Figure 2. The centrifugal force (F_1) developed by the rotary motion of the friction shoe impresses it against the drum creating friction (F_2) between the shoe and the drum.

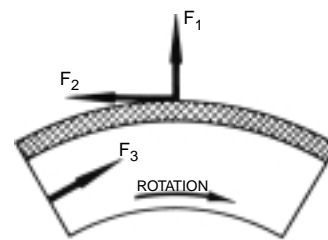

Figure 2

As the drive increases in speed, the centrifugal force increases and thus frictional force increases. When the frictional force reaches sufficient magnitude, it overcomes the resistance of the load, and the clutch drives. At full load speed, the shoe is "locked" firmly against the drum and no slippage occurs.

In engine and turbine applications, where it is necessary to "warm up" before attempting to drive a load, a spring controlled clutch is used. Figure 3 shows a typical spring controlled shoe. Here, a flat spring is placed over pins which run through the base of the shoe. This spring is retained in slots which are milled in the legs of the spider creating additional forces (F_s) which are applied to the friction shoes. The thickness of the spring utilized determines at what speed the particular drive may idle while warming up. At this idling speed, force (F_1) developed by the rotation is not of sufficient magnitude to overcome the total spring force ($2F_s$) acting in the opposite direction on the friction shoe. As the speed of the drive increases above the point at which the spring force (F_s) and the centrifugal force (F_1) are balanced, the shoe is pressed against the drum creating a friction force. The operation from this point on is as described above.

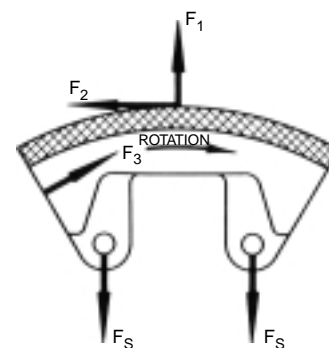

Figure 3



Figure 4

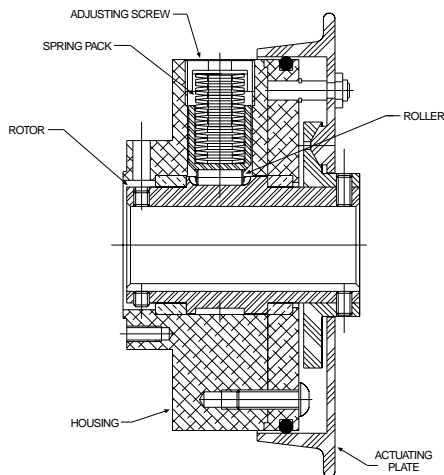

Figure 5

TRI-O-MATIC LITE OVERLOAD CLUTCHES LOR SERIES

FEATURES

- Simple cost-effective design
- Bi-directional operation
- Single position reset
- Reliable limit switch actuating plate
- Easy torque adjustment
- Accurate and repeatable torque settings of 10%
- Maximum torque limit stop
- Through shaft or end shaft mounting
- Straight bore bushings for mounting and stocking flexibility
- Split taper bore bushings for secure mounting
- Large bore capacity (See Figure 4)

OPERATING PRINCIPLES

The LOR Series Trig-O-Matic Lite is an automatic reset, roller detent style clutch. It was designed to be cost-effective without sacrifice to accurate and dependable disconnect protection for mechanical equipment. Refer to *Figure 5*.

Torque transmission between the roller and the rotor is the key to the disengagement of the clutch. The roller is forced into the detent of the rotor by a radial load generated by compressing a spring pack. This load determines the torque capacity of the clutch. Increasing or decreasing the spring compression provides an adjustment to the torque capacity. When a torque overload condition occurs, the roller moves out of the detent and free-wheels much like a needle bearing.

SELECTION

1. Determine overload release torque by one of these methods:
 - a. Use the torque formula with horsepower and RPM specific to the selected clutch location. A service factor may be required for high inertia starts, reversing or peak load conditions.

$$\text{Torque (Lb.In.)} = \frac{\text{HP} \times 63025}{\text{RPM}}$$
 - b. Determine the "weak link" in the drive train, (i.e. chain, reducer, belt or shaft). Select an overload release torque that is below the "weak link's" maximum torque rating.
 - c. Physically measure the drive torque with a torque wrench and size accordingly.
2. Determine the bore size, keyway, and taper bore or straight bore bushing model.
3. Refer to the Basic Selection Chart for the appropriate clutch size. (See Figure 6)
4. Refer to the Boston Gear Centric Catalog for ratings and dimensions.
5. Refer to the Boston Gear Centric Catalog for recommended mounting locations.

BASIC SELECTION CHART

Clutch Size	Max. Bore (In.)		Torque Range (Lb. In.)	Maximum RPM
	Straight	Taper		
060	1.4375	1.1250	200-700	1,000
200	2.1250	1.7500	600-2,000	1,000
400	2.7500	2.2500	2,000-5,000	600

*Larger bores may require reduced keys (supplied with unit)

Figure 6

TORQUE ADJUSTMENT

Each clutch is tested throughout the torque range then set at the minimum torque range value at the factory. The torque dial label is indexed to a match mark on the clutch at the number "1" location. The torque dial label has eight hash marks evenly spaced at 45 degrees. To increase the torque, loosen the locking screw and turn the adjusting screw lockwise. When the desired torque value is achieved, secure the torque adjustment screw by tightening the locking screw. (See Figure 7)

TORQUE ADJUSTMENT

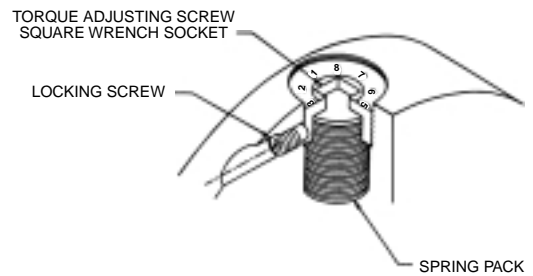

Figure 7

COMMON APPLICATIONS:
packaging machinery, paper converting machinery, baking equipment, bottling and capping machinery, indexing machinery, labeling machinery, conveyors, presses and water treatment equipment.

TRI-O-MATIC LITE OVERLOAD CLUTCHES ORC SERIES

FEATURES

- Bi-directional operation
- Single positioning for re-engagement at the exact cycle point at which it released
- Adjustable torque setting with accuracy of 10%
- Limit switch actuation for remote detection of overload condition
- Completely enclosed for dirty applications
- Automatic or manual reset
- Various configurations for direct and indirect drives
- Six sizes (Model F – five sizes) to accommodate various bore and torque ranges

The Trig-O-Matic's unique "Trigger" action design disconnects the load at the instant an overload occurs and at the exact torque limit you set. When the overload condition is corrected, the clutch resets at the exact cycle point and torque at which it released.

The ORC Series Trig-O-Matic Overload Clutch is available in two models: the Standard Model S and the Fully Automatic Model F. (See Figure 8) Both provide single position engagement and a means to signal an overload condition.

APPLICATIONS

The ORC Series Trig-O-Matic Overload Release Clutch can be applied on any drive train where the protection of reducers, indexers, chain, sprockets or product is required.

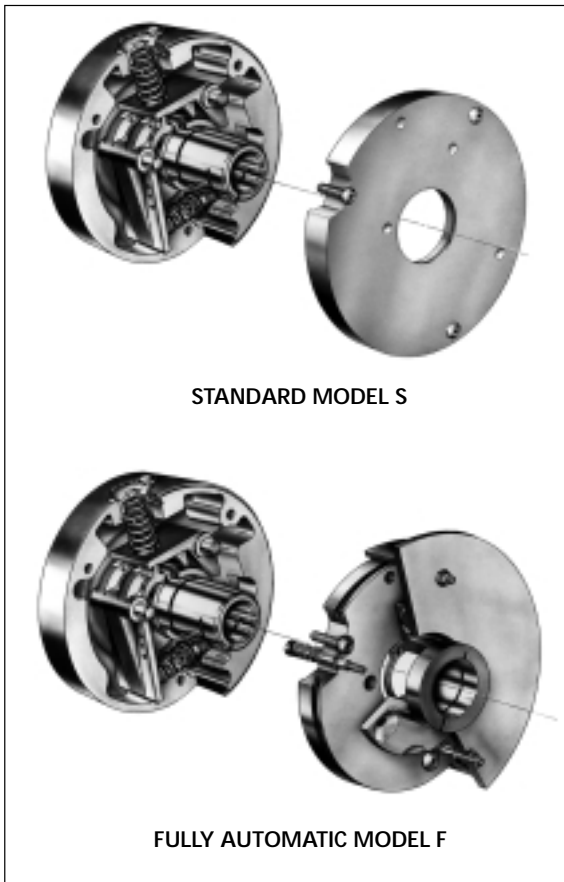

Figure 8

SELECTION

The **Standard Model S** is Boston Gear's basic low-cost unit on which various optional features can be added. The clutch mechanism is available in automatic or manual reset. Typically, a manual reset clutch is used where it will run disengaged for extended periods of time. The automatic reset is generally used in conjunction with a limit switch to shut the drive down. The Standard Model is typically used to replace shear pins and where access to the clutch is available.

The **Fully Automatic Model F** includes all the features available in the Standard Model plus an automatic switch actuating mechanism, an automatic clutch mechanism and three mounting styles. The Model F is generally used where the unit is not easily accessible. This model is a complete overload clutch designed especially for production and packaging machinery.

See how these popular models compare in *Figure 9*.

TRIG-O-MATIC ORC SERIES STANDARD MODEL S

OPERATING PRINCIPLES

The standard Model S ORC Series Trig-O-Matic Overload Release Clutch consists of two basic components: the rotor and the housing assembly. The clutch rotor is keyed and secured with a setscrew.

The housing assembly includes a drive pawl and a reset pawl, which are pivoted within the clutch housing. The drive pawl is held engaged in the rotor notch by the combined pressure of the drive and reset springs as shown in *Figure 10*. The combined pressure of these two springs determines the maximum torque that is transmitted without overload. With the clutch mechanism in the engaged position shown in *Figure 10*, the rotor and housing are held together and the entire unit rotates with the drive shaft at the same speed.

TRIG-O-MATIC MODEL FEATURE COMPARISONS

ORC Series Model S	ORC Series Model F
Bi-directional	Bi-directional
Single Position	Single Position
Manual Clutch Reset	Automatic Clutch Reset
Automatic Clutch Reset	Automatic Clutch Reset
Clutch Types B, C, N, R, T	Clutch Types B, C, N, R, T
One Mounting Style	Three Mounting Styles
Limit Switch Pin	Fully Automatic
Limit Switch Plate Actuator	Limit Switch Plate Actuator
Additional Features: Torque Selector Dial Max. Torque Limit Stop Grease Pack & Relief Fittings	Additional Features: Torque Selector Dial Max. Torque Limit Stop Grease Pack & Relief Fittings Locking Collar Mounting
Optional: Pressure Lube Bearings Balancing Locking Collar Mounting	Optional: Balancing One-Directional Feature

Figure 9

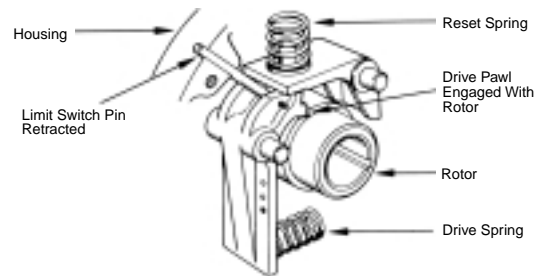

The Standard Model Trig-O-Matic is available in two clutch reset types: Manual and Automatic.

Figure 10, Model S Engaged

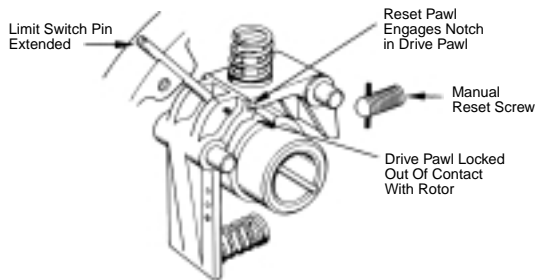

Figure 11, Disengaged - Manual

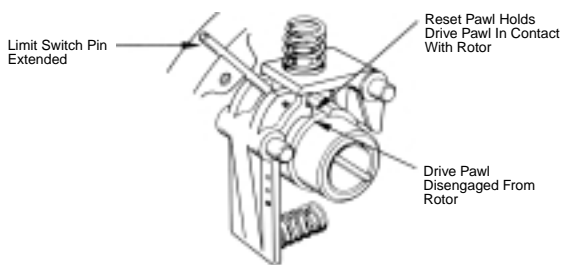

Figure 12, Disengaged - Automatic

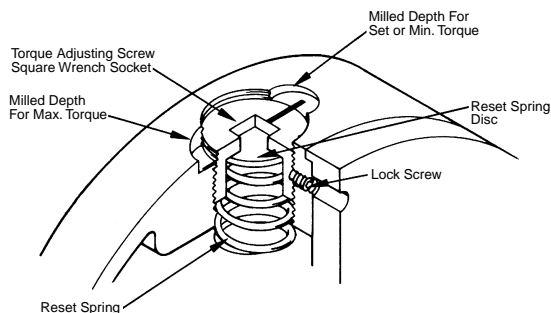

Figure 13

MANUAL RESET

The instant an overload occurs, the pressure of the drive and reset springs is overcome by the extra force applied to them. The drive pawl is forced out of its engaged position from the rotor and as it pivots up, the reset pawl lifts and locks it out of contact with the rotor as shown in *Figure 11*. The clutch then rotates freely.

When the overload condition has been corrected, the clutch is reset by inserting a hexagon wrench in the reset screw and turning the screw clockwise until the reset pawl releases the drive pawl. When the drive pawl re-engages with the rotor, the reset screw must be backed out to its original stop position. This is essential to restore the torque to its original setting.

AUTOMATIC RESET

The instant an overload occurs, the pressure of the drive and reset springs is overcome by the extra force applied to them. The drive pawl is forced out of its engaged position from the rotor. The reset pawl applied pressure to the top of the drive pawl, holding it in contact with the rotor as shown in *Figure 12*. After one revolution the drive pawl will automatically return to its engaged position.

The drive should be stopped as soon as possible. After the overload condition has been corrected the drive must be "jogged" until the drive pawl engages with the rotor.

LIMIT SWITCH PIN

A limit switch pin is furnished as a standard item to activate a limit switch that triggers the electrical controls. The travel of the limit switch pin protruding radially from the clutch housing is controlled by the drive pawl motion upon disengagement. The limit switch pin can be used if the housing continues to turn when an overload occurs and the rotor stops, (i.e., the housing is the driver and the rotor is the driven). The housing RPM must be considered to determine the time for the limit switch pin to revolve around before contacting the limit switch.

TORQUE SELECTOR DIAL

The torque selector dial shown in *Figure 13* is a standard feature on all Standard Model S Trig-O-Matic clutches. Each clutch is individually calibrated to specific torque values. The housing has two milled marks indicating minimum and maximum torque.

H1600 OVERLOAD CLUTCHES HOR SERIES

FEATURES

- Bi-direction operation
- Single position indexing
- Automatic reset
- Accurate and dependable disconnection, 10% of torque setting
- Convenient torque adjustment
- Maximum torque limit stop
- Limit switch actuating mechanism
- Clamp collar for secure mounting
- Hardened components for long life
- Electroless nickel finish and stainless steel hardware for superior corrosion resistance (See Figure 14)



Figure 14

OPERATING PRINCIPLES

The HOR Series H1600 is an automatic reset ball detent style overload release clutch. It has been designed to provide accurate and dependable torque disconnect protection for mechanical power transmission equipment. Torque is transmitted through the clutch in one of two paths. Refer to Figure 15.

Torque transmission between the balls and housing is the key to the disengagement of the clutch. The balls are forced into the pockets of the housing by an axial load generated by a compressing spring pack. The axial load determines the torque capacity of the clutch. Increasing or decreasing the spring compression or changing spring packs provides a means for multiple torque adjustments. When a torque overload condition occurs, the balls roll out of the pockets and freewheel much as a ball thrust bearing.

The movement of the cover during disengagement can be used to trip a limit switch and signal a torque overload condition.

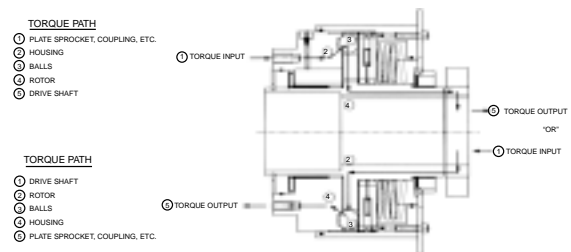

Figure 15



Figure 16

H1900 OVERLOAD CLUTCHES FOR THE WASTE-WATER TREATMENT INDUSTRY WOR SERIES

FEATURES

- Automatic or manual reset
- Large bore capacity
- Through shaft or end shaft mounting
- Accurate torque release
- Stainless steel enclosure
- Electroless nickel plated
- Adaptable for all drives
- Operating parts are hardened for long life (See Figure 16)

OPERATING PRINCIPLES

The WOR Series H1900 is a mechanical ball detent overload release clutch. It has been designed to provide accurate and dependable torque overload protection for mechanical water and wastewater treatment equipment.

Torque is transmitted between the balls and the detents of the rotor in the following manner:

The chrome alloy balls are forced into the detents of the 50 Rc hardened rotor by an axial load generated by compressing a spring pack. This axial load is what determines the torque capacity of the clutch. Increasing or decreasing the spring compression or changing spring packs provides a means for multiple torque adjustments. When a torque overload condition occurs, the balls roll out of the rotor detents. This rolling action reduces any fluctuation in torque due to frictional changes (See Figure 17).

The movement of the cover during disengagement of the balls can be used to trip a limit switch and signal an overload condition.

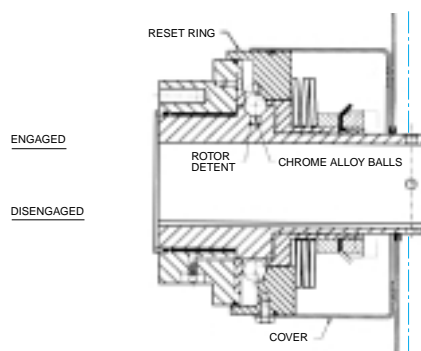

Figure 17

WATER AND WASTEWATER TREATMENT APPLICATIONS

Overload release clutches can be installed to provide positive protection against damaging jams to the drives. They are located on the output sides of speed reducers, or as near as possible to the potential source of the overload so that the drive components are adequately protected.

The completely sealed clutches are suitable for outdoor installations, including a stainless steel cover, electroless nickel plated external parts, and an external grease fitting for packing the units.

H2000 PNEUMATIC OVERLOAD CLUTCHES POR SERIES

FEATURES

- "In-Flight" torque control offers precise pneumatic torque control
- Remotely adjustable for starting and overrunning loads
- Bi-directional operation
- Single position indexing
- Automatic reset
- Accurate and dependable disconnection, 10% of torque setting
- Through-shaft design
- Limit switch actuating mechanism
- Clamp collar for secure mounting
- Hardened parts for long clutch life
- Internal needle roller thrust bearings
- Lubrication fittings
- Sealed from environmental contamination
- Electroless nickel finish and stainless steel hardware for superior corrosion resistance (*See Figure 18*)



Figure 18

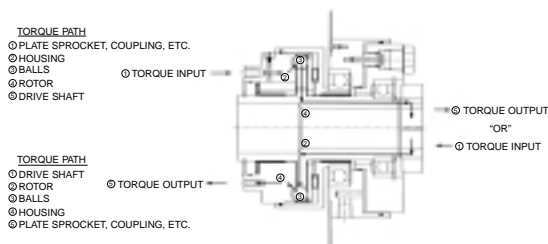

Figure 19



Figure 20

OPERATING PRINCIPLES

The POR Series H2000 is a pneumatic, ball detent style overload release clutch. It has been designed to provide accurate and dependable torque disconnect protection for mechanical power transmission equipment. Torque is transmitted through the clutch in one of two paths. (Refer to Figure 19).

Torque transmission between the balls and housing is the key to the disengagement of the clutch. The balls are forced into the pockets of the housing by an axial load generated by an air cylinder. Increasing or decreasing the air pressure provides a means for remotely controlled precise "in-flight" torque adjustment. When a torque overload condition occurs, the balls roll out of the pockets and free wheel much as a ball thrust bearing.

The clutch has been designed with an internal valving mechanism. During an overload condition, the air is purged instantaneously from the cylinder.

The movement of the air cylinder during disengagement can be used to trip a limit switch and signal a torque overload condition. To engage the clutch, reapply air pressure and job the drive until the clutch engages. Adjust the release torque by increasing the air pressure supplied to the clutch to reach the desired torque value. The clutch is now ready for normal operation.

PNEUMATIC CONTROL

Boston Gear offers a pneumatic control for use with POR Series H2000® overload release clutches. (See Figure 20)

This control allows you to regulate the system efficiently with dual air pressures. During start-up, the clutch may be required to transmit a higher torque due to the high starting inertia of the drive. Higher air pressure can be used to transmit this torque without prematurely disengaging the clutch. Once the drive has reached its operating speed, a lower operating torque may be seen by the clutch. Lower air pressure can be used to reduce the overload release point of the clutch to safely operate the drive at running speeds.

VARITORQUE PNEUMATIC OVERLOAD CLUTCHES VOR SERIES

FEATURES

- "In-Flight" torque control. Precise torque control adjustable for starting and overrunning loads
- Single positioning for re-engagement at the exact cycle point at which it released
- Torque accuracy within 5%
- Bi-directional operation
- Electroless nickel finish
- Six point drive engagement
- Automatic disconnect
- Deublin flange mounted air union
- Automatic switch actuating plate for instantaneous remote detection of overload condition
- Completely enclosed for "dirty" applications
- Pressure lubrication
- Positive split locking collar for secure shaft mounting
- Operates on static air pressure (20-80 psi), no elaborate air systems required (*See Figure 21*)

OPERATING PRINCIPLES – AIR UNION

The air pressure supplied to the clutch enters through the hex steel rotor of the Deublin air union. When the VOR Series VariTorque is engaged and operating, the union rotor is the only stationary part. The union housing rotates on a double row ball bearing protected by dirt-tight seals. A spring-loaded carbon micro-lapped seal prevents air leakage between the rotor and housing of the union. The air passes through the union housing into the cylinder assembly of the VariTorque.



Figure 21

AIR PRESSURE AND TORQUE CAPACITY

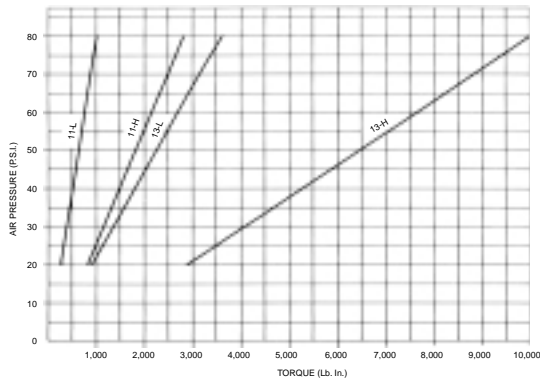

Figure 22

CYLINDER ASSEMBLY

Air pressure acts against the surface area of the piston exerting a force to move the piston against the pressure pins. Resulting torque ranges (see Figure 22) are developed by different size piston surface areas of the two cylinder sizes, (L-small, H-large).

GENERAL INFORMATION – AIR CONTROLS

The high pressure regulator should be set at a pressure just high enough to permit the VariTorque clutch to overcome any **momentary overload torques** caused during the machine's start-up and stopping period.

The low pressure regulator should be at a pressure just low enough to permit the VariTorque clutch to overcome the **normal operating torques** caused during the machine's running period and to permit a crisp and positive re-engagement of the VariTorque clutch should an overload occur.

CENTRIC CLUTCHES

CENTRIC CLUTCHES

SELECTION GUIDE

To select or order a Boston Gear Centric Clutch, please complete the following information and fax this form to Product Support at 1-800-752-4327.

GENERAL INFORMATION

Company		
Address	City	State
Contact Person	Tel. No.	Fax No.

APPLICATION DATA

<p>1. Drive method: <input type="checkbox"/> Electric Motor <input type="checkbox"/> Engine/Turbine <input type="checkbox"/> Other</p> <p>2. Method of drive: <input type="checkbox"/> Direct <input type="checkbox"/> Indirect (provide sketch)</p> <p>3. Power transmission requirements at clutch location: Horsepower _____ RPM _____</p> <p>4. Type: <input type="checkbox"/> Standard (A) <input type="checkbox"/> Vertical Lift-Out (V)</p> <p>5. Used as Overload Protection Device: <input type="checkbox"/> Yes <input type="checkbox"/> No</p> <p>6. Speeds (required for engines, turbines, dual drives): Idling _____ RPM Engagement _____ RPM Disengagement _____ RPM</p> <p>7. Bores: Driver (input) _____ inches Driver (output) _____ inches</p> <p>8. Service Factor Required: _____</p>
--

Use the space below to sketch any relevant application data:

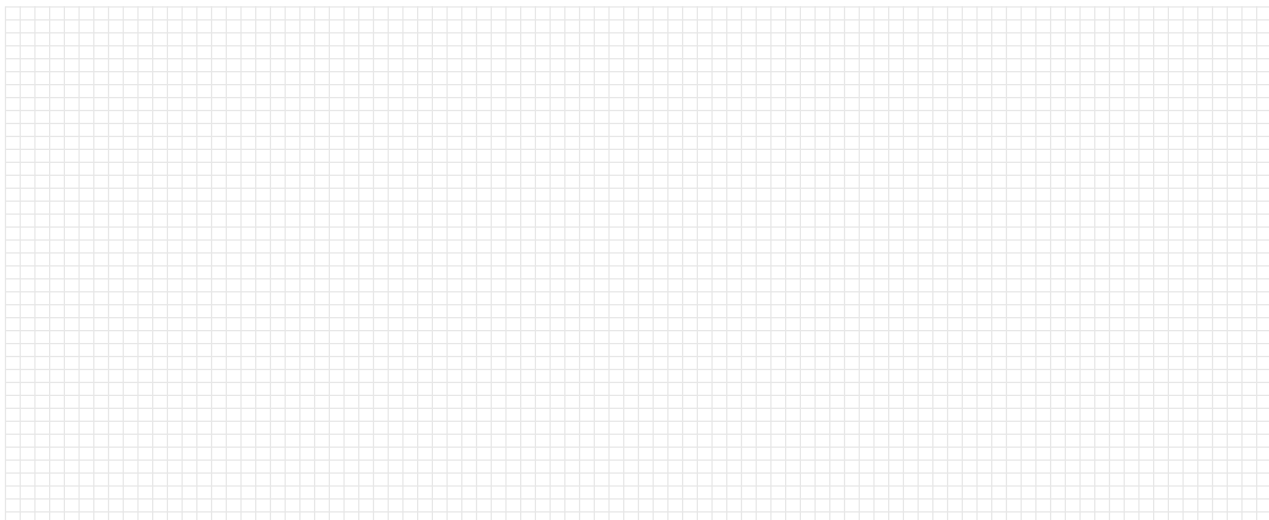

Quiz

CLICK HERE or visit <http://www.bostongear.com/quiz> to take the quiz